

MM74C93 4-Bit Binary Counter

General Description

The MM74C93 binary counter and complementary MOS (CMOS) integrated circuits constructed with N- and P-channel enhancement mode transistors. The 4-bit binary counter can be reset to zero by applying high logic level on inputs R_{01} and R_{02} , and a separate flip-flop on the A-bit enables the user to operate it as a divide-by-2, -8, or -16 divider. Counting occurs on the negative going edge of the input pulse.

All inputs are protected against static discharge damage.

Features

- Wide supply voltage range: 3V to 15V
- Guaranteed noise margin: 1V
- High noise immunity: 0.45 V_{CC} (typ.)
- Low power compatibility:
Fan out of 2 TTL driving 74L
- The MM74C93 follows the MM74L93 Pinout

Ordering Code:

Order Number	Package Number	Package Description
MM74C93N	N14A	14-Lead Plastic Dual-In-Line Package (PDIP), JEDEC MS-001, 0.300" Wide

Connection Diagram

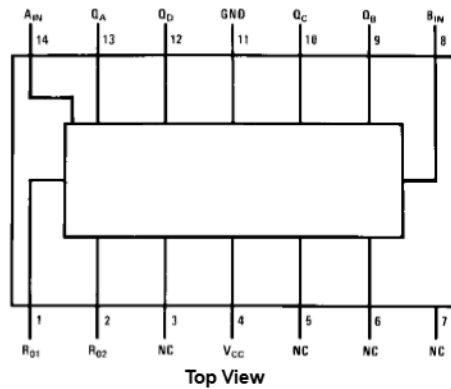

Truth Table

4-Bit Binary Counter Binary Count Sequence

Count	Output			
	Q_D	Q_C	Q_B	Q_A
0	L	L	L	L
1	L	L	L	H
2	L	L	H	L
3	L	L	H	H
4	L	H	L	L
5	L	H	L	H
6	L	H	H	L
7	L	H	H	H
8	H	L	L	L
9	H	L	L	H
10	H	L	H	L
11	H	L	H	H
12	H	H	L	L
13	H	H	L	H
14	H	H	H	L
15	H	H	H	H

Logic Diagram

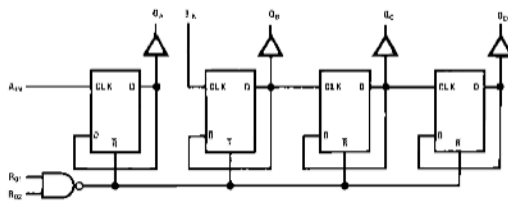

Output Q_A is connected to input B for binary count sequence.
H = HIGH Level
L = LOW Level
X = Irrelevant

Function Tables

Reset/Count Function Table

Reset Inputs				Output			
R ₀₁	R ₀₂	R ₉₁	R ₉₂	Q _D	Q _C	Q _B	Q _A
H	H	L	X	L	L	L	L
H	H	X	L	L	L	L	L
X	X	H	H	H	L	L	H
X	L	X	L				Count
L	X	L	X				Count
L	X	X	L				Count
X	L	L	X				Count

Reset/Count Function Table

Reset Inputs		Output			
R ₀₁	R ₀₂	Q _D	Q _C	Q _B	Q _A
H	H	L	L	L	L
L	X				Count
X	L				Count

Absolute Maximum Ratings(Note 1)

Voltage at Any Pin (Note 1)	-0.3V to $V_{CC} + 0.3V$
Operating Temperature Range (T_A)	-55°C to +125°C
Power Dissipation (P_D)	
Dual-In-Line	700 mW
Small Outline	500 mW
Operating V_{CC} Range	3V to 15V
Absolute Maximum V_{CC}	18V
Storage Temperature Range (T_S)	-65°C to +150°C
Lead Temperature (T_L)	
(Soldering, 10 seconds)	260°C

Note 1: "Absolute Maximum Ratings" are those values beyond which the safety of the device cannot be guaranteed. Except for "Operating Temperature Range", they are not meant to imply that the devices should be operated at these limits. The table of "Electrical Characteristics" provides conditions for actual device operation.

DC Electrical Characteristics

Min/Max limits apply across temperature range unless otherwise noted

Symbol	Parameter	Conditions	Min	Typ	Max	Units
CMOS TO CMOS						
$V_{IN(1)}$	Logical "1" Input Voltage	$V_{CC} = 5V$ $V_{CC} = 10V$	3.5 8.0			V
$V_{IN(0)}$	Logical "0" Input Voltage	$V_{CC} = 5V$ $V_{CC} = 10V$			1.5 2.0	V
$V_{OUT(1)}$	Logical "1" Output Voltage	$V_{CC} = 5V, I_O = -10 \mu A$ $V_{CC} = 10V, I_O = -10 \mu A$	4.5 9.0			V
$V_{OUT(0)}$	Logical "0" Output Voltage	$V_{CC} = 5V, I_O = +10 \mu A$ $V_{CC} = 10V, I_O = +10 \mu A$			0.5 1.0	V
$I_{IN(1)}$	Logical "1" Input Current	$V_{CC} = 15V, V_{IN} = 15V$		0.005	1.0	μA
$I_{IN(0)}$	Logical "0" Input Current	$V_{CC} = 15V, V_{IN} = 0V$	-1.0	-0.005		μA
I_{CC}	Supply Current	$V_{CC} = 15V$		0.05	300	μA
CMOS/LPTTL INTERFACE						
$V_{IN(1)}$	Logical "1" Input Voltage MM74C90, MM74C93	$V_{CC} = 4.75V$		$V_{CC} - 1.5$		V
$V_{IN(0)}$	Logical "0" Input Voltage MM74C90, MM74C93	$V_{CC} = 4.75V$			0.8	V
$V_{OUT(1)}$	Logical "1" Output Voltage MM74C90, MM74C93	$V_{CC} = 4.75V, I_O = -360 \mu A$	2.4			V
$V_{OUT(0)}$	Logical "0" Output Voltage MM74C90, MM74C93	$V_{CC} = 4.75V, I_O = -360 \mu A$			0.4	V
OUTPUT DRIVE (See Family Characteristics Data Sheet) (Short Circuit Current)						
I_{SOURCE}	Output Source Current (P-Channel)	$V_{CC} = 5V, V_{OUT} = 0V$ $T_A = 25^\circ C$	-1.75	-3.3		mA
I_{SOURCE}	Output Source Current (P-Channel)	$V_{CC} = 10V, V_{OUT} = 0V$ $T_A = 25^\circ C$	-8.0	-15		mA
I_{SINK}	Output Sink Current (N-Channel)	$V_{CC} = 5V, V_{OUT} = V_{CC}$ $T_A = 25^\circ C$	1.75	3.6		mA
I_{SINK}	Output Sink Current (N-Channel)	$V_{CC} = 10V, V_{OUT} = V_{CC}$ $T_A = 25^\circ C$	8.0	16		mA

AC Electrical Characteristics (Note 2)						
$T_A = 25^\circ\text{C}$, $C_L = 50\text{ pF}$, unless otherwise specified						
Symbol	Parameter	Conditions	Min	Typ	Max	Units
t_{pd0} , t_{pd1}	Propagation Delay Time from A_{IN} to Q_A	$V_{CC} = 5V$ $V_{CC} = 10V$		200 80	400 150	ns
t_{pd0} , t_{pd1}	Propagation Delay Time from A_{IN} to Q_B (MM74C93)	$V_{CC} = 5V$ $V_{CC} = 10V$		450 160	850 300	ns
t_{pd0} , t_{pd1}	Propagation Delay Time from A_{IN} to Q_B (MM74C90)	$V_{CC} = 5V$ $V_{CC} = 10V$		450 160	800 300	ns
t_{pd0} , t_{pd1}	Propagation Delay Time from A_{IN} to Q_C (MM74C93)	$V_{CC} = 5V$ $V_{CC} = 10V$		500 200	1050 400	ns
t_{pd0} , t_{pd1}	Propagation Delay Time from A_{IN} to Q_C (MM74C93)	$V_{CC} = 5V$ $V_{CC} = 10V$		500 200	1000 400	ns
t_{pd0} , t_{pd1}	Propagation Delay Time from A_{IN} to Q_D (MM74C93)	$V_{CC} = 5V$ $V_{CC} = 10V$		600 250	1200 500	ns
t_{pd0} , t_{pd1}	Propagation Delay Time from A_{IN} to Q_D (MM74C90)	$V_{CC} = 5V$ $V_{CC} = 10V$		450 160	800 300	ns
t_{pd0} , t_{pd1}	Propagation Delay Time from R_{01} or R_{02} to Q_A , Q_B , Q_C or Q_D (MM74C93)	$V_{CC} = 5V$ $V_{CC} = 10V$		150 75	300 150	ns
t_{pd0} , t_{pd1}	Propagation Delay Time from R_{01} or R_{02} to Q_A , Q_B , Q_C or Q_D (MM74C90)	$V_{CC} = 5V$ $V_{CC} = 10V$		200 75	400 150	ns
t_{pd0} , t_{pd1}	Propagation Delay Time from R_{01} or R_{02} to Q_A or Q_D (MM74C90)	$V_{CC} = 5V$ $V_{CC} = 10V$		250 100	500 200	ns
t_{PW}	Min. R_{01} or R_{02} Pulse Width (MM74C93)	$V_{CC} = 5V$ $V_{CC} = 10V$	600 30	250 125		ns
t_{PW}	Min. R_{01} or R_{02} Pulse Width (MM74C90)	$V_{CC} = 5V$ $V_{CC} = 10V$	600 300	250 125		ns
t_{PW}	Min. R_{01} or R_{02} Pulse Width (MM74C90)	$V_{CC} = 5V$ $V_{CC} = 10V$	500 250	200 100		ns
t_r , t_f	Maximum Clock Rise and Fall Time	$V_{CC} = 10V$ $V_{CC} = 10V$			15 5	μs
t_W	Minimum Clock Pulse Width	$V_{CC} = 5V$ $V_{CC} = 10V$	250 100	100 50		ns
f_{MAX}	Maximum Clock Frequency	$V_{CC} = 5V$ $V_{CC} = 10V$	2 5			MHz
C_{IN}	Input Capacitance	Any Input (Note 3)		5		pF
C_{PD}	Power Dissipation Capacitance	Per Package (Note 4)		45		pF

Note 2: AC Parameters are guaranteed by DC correlated testing.

Note 3: Capacitance is guaranteed by periodic testing.

Note 4: C_{PD} determines the no load ac power consumption of any CMOS device. For complete explanation see Family Characteristics application note—AN-90.

AC Test Circuits

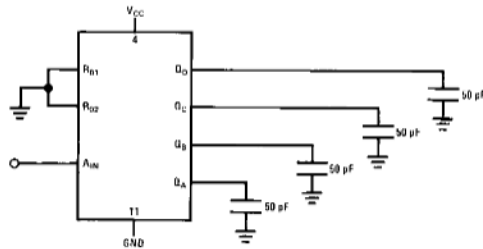

Clock rise and fall time $t_r = t_f = 20$ ns

Switching Time Waveforms

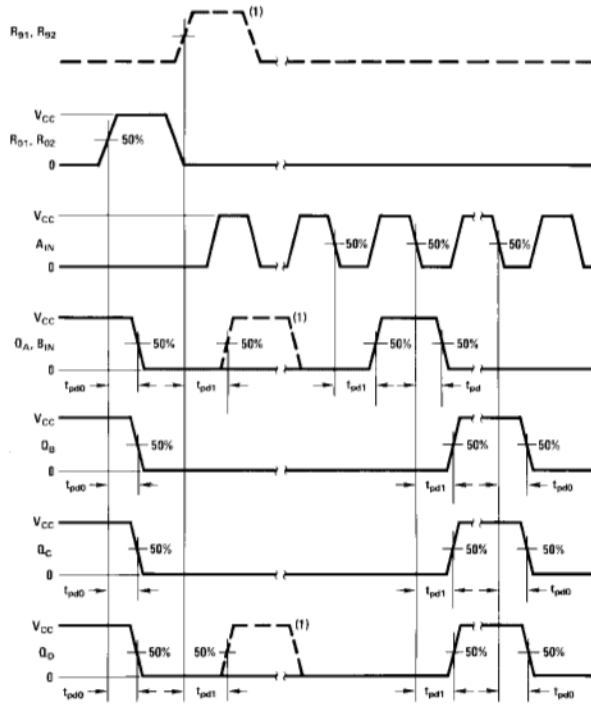

MM74C90 and MM74C93 are solid line waveforms. Dashed line waveforms are for MM74C90 only.

Physical Dimensions inches (millimeters) unless otherwise noted

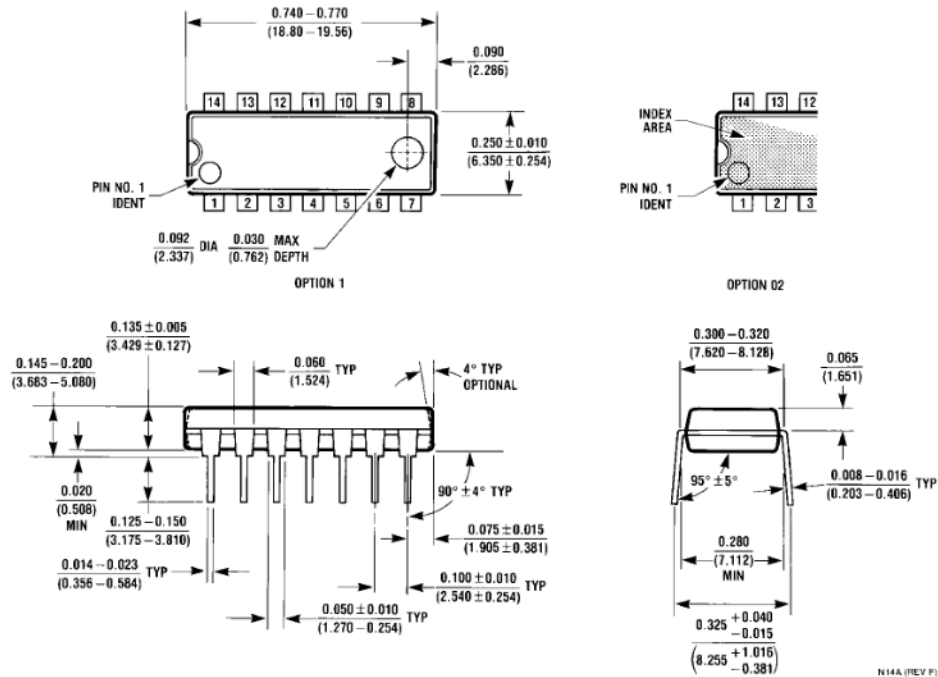

**14-Lead Plastic Dual-In-Line Package (PDIP), JEDEC MS-001, 0.300" Wide
Package Number N14A**

Fairchild does not assume any responsibility for use of any circuitry described, no circuit patent licenses are implied and Fairchild reserves the right at any time without notice to change said circuitry and specifications.

LIFE SUPPORT POLICY

FAIRCHILD'S PRODUCTS ARE NOT AUTHORIZED FOR USE AS CRITICAL COMPONENTS IN LIFE SUPPORT DEVICES OR SYSTEMS WITHOUT THE EXPRESS WRITTEN APPROVAL OF THE PRESIDENT OF FAIRCHILD SEMICONDUCTOR CORPORATION. As used herein:

1. Life support devices or systems are devices or systems which, (a) are intended for surgical implant into the body, or (b) support or sustain life, and (c) whose failure to perform when properly used in accordance with instructions for use provided in the labeling, can be reasonably expected to result in a significant injury to the user.
2. A critical component in any component of a life support device or system whose failure to perform can be reasonably expected to cause the failure of the life support device or system, or to affect its safety or effectiveness.

www.fairchildsemi.com